

# Gamut Clipping in Color Image Processing

Christopher C. Yang

Department of Systems Engineering and Engineering  
Management  
The Chinese University of Hong Kong  
Hong Kong SAR  
yang@se.cuhk.edu.hk

S. H. Kwok

Department of Information and Systems Management  
The Hong Kong University of Science and Technology  
Hong Kong SAR  
jkwok@ust.hk

## Abstract

Multiple color coordinate systems are usually involved in color image applications or systems. Forward and backward transformations are used to switch between color coordinate systems. The out of gamut problem emerges when the color coordinate systems' gamut is different. Conventional approaches, including clipping R, G, B values and clipping luminance value are not ideal as they both produce severe error in the luminance component of the resulting color or reduce the contrast of the resulting image. We propose to clip the saturation value when a vector is out of the gamut of the LHS or YIQ space using the saturation processing equations. We have conducted experiments to compare three different clipping approaches. The experimental results show that the saturation clipping approach outperforms the other two approaches, in the sense that it can keep the luminance value unchanged. In addition, the contrast of the image produced by saturation clipping is much better than those produced by other clipping approaches.

## 1 Introduction

In essence, a color model is a specification of a 3-D coordinate system and a single point within the subspace of the system represents a distinct color. Most color coordinate systems in use today can be either hardware-oriented or application-oriented. Color monitors, printers, and televisions are using the hardware-oriented coordinate systems while color image processing and computer graphics are using the application-oriented coordinate systems. The most commonly used hardware-oriented color coordinate system is the RGB (red, green, blue) system, which is widely used for color monitors and broad classes of color video cameras. Another commonly used hardware-oriented color coordinate system is the YIQ system [2, 3] that is the standard for color TV broadcast in United States. In YIQ system, Y corresponds to luminance, and I and Q are two chromatic components corresponding to inphase, and quadrature, respectively. The LHS system is the most frequently used application-oriented color coordinate

systems for color image manipulation, where luminance corresponds to luminance, and H and S corresponds to two chromatic components, hue and saturation.

RGB, YIQ, and LHS are the three most commonly used color coordinate systems. RGB color coordinate system does not correspond to the perceptual attributes of the human visual system (HVS). Thus, it is undesirable to perform image processing on RGB domain. In contrast, LHS and YIQ color coordinate systems are more favorable for color image processing since they both contain components that correspond to perceptual attributes, luminance, hue and saturation.

In many color processing systems and applications, RGB color coordinate system is used to represent the image, while other two color coordinate systems, LHS, and YIQ are used for color manipulation. When more than one color coordinate systems are in use, forward and backward transformations between two color coordinate systems are required [4, 5]. These transformations must be carefully designed to handle the out of gamut problem. Otherwise, the transformed color can be greatly different from the expected color after transformation. If color image processing is conducted on the LHS or YIQ space, the vector [L, H, S] or [Y, I, Q] may fall out of the gamut after color image processing. It is because the gamut of LHS or YIQ does not fully occupy the cylindrical space but only a subset of the cylindrical space. This is called the out of gamut problem. This problem occurs frequently in color image processing. G. Marcu and S. Abe [1] reported the out of gamut problem occurs in color reproduction in different devices, such as color printers, and CRTs. It is a common and practical example. However, this paper focuses on the three common color models, and therefore their solution toward hardware devices cannot be applied. There are two simple solutions to this problem: (1) transforming out of gamut vector in LHS space back to RGB space and clip the R, G, or B values if it is out of the allowable range, and (2) clip the

luminance value of the vector in LHS space until it falls inside the gamut of the LHS space.

In this paper, we propose to clip the saturation values when the vector is out of the gamut of the LHS or YIQ space using the saturation processing equations. In view of losing contrast by clipping luminance, an alternative approach is saturation clipping. Clipping saturation may keep the contrast of the processed color images and the hue of each processed pixel. Indeed, the allowable range of saturation decreases as the luminance increases. When the luminance is maximum, the only allowable value of saturation is zero and the color is pure white. Clipping saturation does not affect the image visually.

## 2 Color Coordinate Systems

For computer applications, color is usually described in terms of red, green, and blue (RGB) color coordinate system. For examples, color images originating from digital camera or digital scanners are represented in RGB format, and the red, green and blue phosphor dots on a color CRT display the arbitrary colors. Although the RGB color coordinate system is widely used in the computer application, color coordinate systems that represent the human perception of color are more preferable for color image processing. For examples, LHS and YIQ are color coordinate systems, which one coordinate represents luminance and two other coordinates jointly represent chromatic attributes.

In color image processing, one can transform the RGB values of each pixel in the color image to LHS (or YIQ) values. The L component (or Y component) is then taken for the luminance processing. The processed luminance component, L' (or Y'), together with the original hue and saturation (or I and Q) will then be transformed back to the RGB values for each corresponding pixel. The whole process is shown in Figure 1.

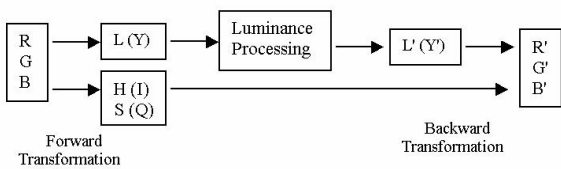

Figure 1. Luminance processing for color images using LHS and YIQ color coordinate systems.

The input and output images for color image processing are using the RGB color coordinate system while the processing itself is using other color coordinate systems (LHS and YIQ). In view of the different color coordinate systems being used in the input, output and

processing, the gamut of the color coordinate systems is important to ensure that the color represented by the processing color coordinate system can be transformed back to the RGB color coordinate system. Figure 2 illustrates the gamut problem. The gamut of a color space is the subset of that space which is able to map onto a point within the RGB cube, where R, G and B  $\in [0,1]$ .

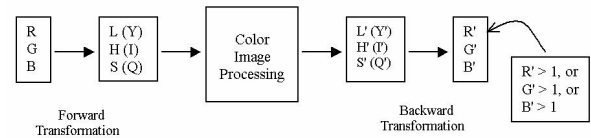

Figure 2. Illustration of the gamut problem in color image processing when the color coordinate system used in input and output is different to the color coordinate system used in processing.

Figure 3 illustrates the gamut of the LHS system particularly on the red, green, and blue hue-plane. For the red hue-plane, the range of saturation is  $[0,1]$  when the luminance is less than or equal to 0.299 (the weight on the red component in the luminance equation). As the luminance increases, the allowable range of saturation decreases and it is  $[0,0]$  when the luminance is maximum, i.e., luminance equals to 1. It is similar for the green and blue hue-plane.

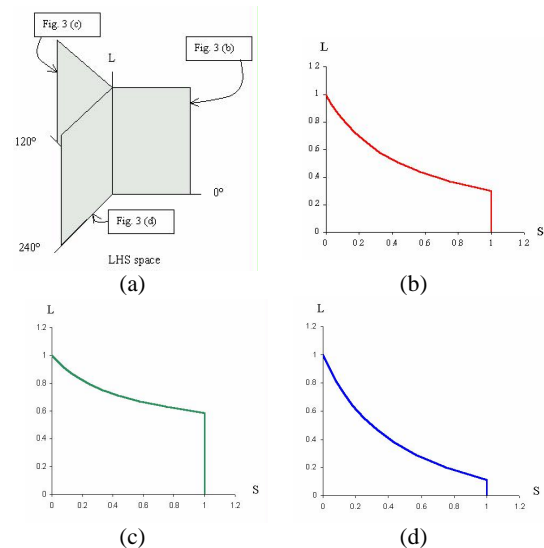

Figure 3. (a) the red hue-plane, green hue-plane, and blue hue-plane in the LHS space, (b) the gamut of LHS color coordinate system on the red hue-plane, (c) the gamut of LHS color coordinate system on the green hue-plane, (d) the gamut of LHS color coordinate system on the blue hue-plane.

### 3 Gamut Clipping

Color image processing is conducted on the LHS or YIQ space. Since the gamut LHS or YIQ does not fully occupy the cylindrical space but only a subset of the cylindrical space, the vector  $[L,H,S]$  or  $[Y,I,Q]$  may fall out of the gamut after color image processing. For example, the color of a pixel is the vector  $[l,h,s]$  in the LHS space before processing, the luminance,  $l$ , is changed to  $l'$  after processing. The vector  $[l',h,s]$  may no longer inside the gamut of LHS space. This problem occurs frequently in color image processing. There are several typical solutions to this problem: (1) transforming out of gamut vector in LHS space back to RGB space and clip the R, G, or B values if it is out of the allowable range as shown in Figure 4a, and (2) clip the luminance value of the vector in LHS space until it fall inside the gamut of the LHS space as depicted in Figure 4b.

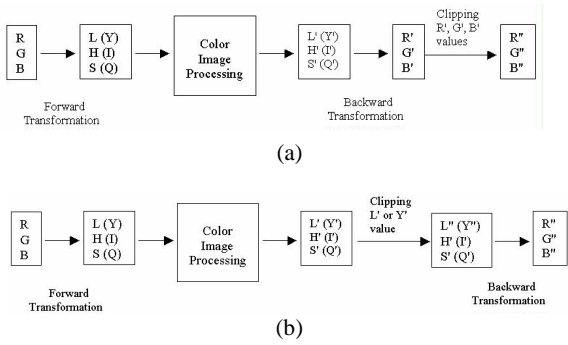

Figure 4. (a) R, G, B clipping after backward transformation, (b) luminance clipping before transformation.

If we take the solution (1) by clipping whichever values of R, G, or B are out of range after backward transformation, the luminance, hue and saturation of the processed pixel will be completely changed in most cases. In particular, the processed color is far away from the gamut, clipping the R, G, or B values will change the color significantly.

If we take the solution (2) by clipping the luminance before the backward transformation, the hue and saturation will be maintained but the luminance will be changed to the clipped value. Using such approach will not change the chromatic attributes but may lose the contrast on the image.

As a result, none of the above approach is ideal for solving the out of gamut problem in color image processing. In this paper, we propose to clip the saturation values when the vector is out the gamut of the

LHS or YIQ space using the saturation processing equations.

In view of losing contrast by clipping luminance, an alternative approach is saturation clipping. Clipping saturation will maintain the contrast of the processed color images and the hue of each processed pixel. Indeed, the allowable range of saturation decreases as the luminance increases. When the luminance is maximum, the only allowable value of saturation is zero and the color is pure white. Clipping saturation does not affect the image visually. Figure 5(a) illustrates luminance clipping.  $P_1$  ( $[L,H,S] = [0.8,0^\circ,0.6]$ ) and  $P_2$  ( $[L,H,S] = [0.6,0^\circ,0.6]$ ) have the same saturation but different luminance. When we apply luminance clipping, they are both clipped to  $P_3$  ( $[L,H,S] = [0.427,0^\circ,0.6]$ ). The luminance of both  $P_1$  and  $P_2$  are both clipped to 0.427. When many pixels in the neighborhood of an color image have close values of hue and saturation but significant difference values in luminance, luminance clipping will clip all these pixels into a small cluster in the LHS space. Therefore, such clipping will cause the loss in contrast. Figure 5(b) illustrates saturation clipping.  $P_1$  and  $P_2$ , same as those in Figure 5(a), are clipped to  $P_3$  ( $[L,H,S] = [0.8,0^\circ,0.117]$ ) and  $P_4$  ( $[L,H,S] = [0.6,0^\circ,0.307]$ ), respectively, when we apply saturation clipping. The luminance of  $P_1$  and  $P_2$  are kept but the saturation is clipped to the maximum allowed value in the LHS space.

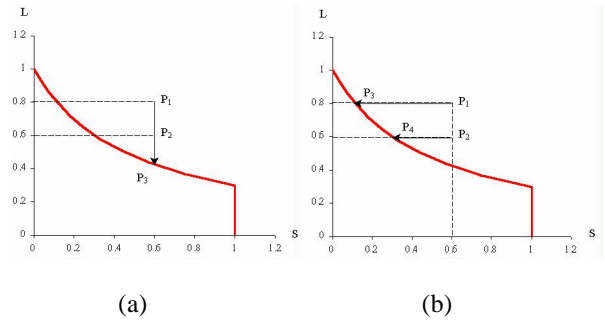

Figure 5. Illustration of (a) luminance clipping and (b) saturation clipping on the red hue-plane of the LHS space.

In order to clip saturation for a vector, which is out of gamut in the LHS space, the equation of saturation processing, Equation (1), is utilized with maximum allowable value of  $\beta$ , where  $\beta$  is determined by Equation (2).

$$\begin{bmatrix} R' \\ G' \\ B' \end{bmatrix} = \beta \begin{bmatrix} R \\ G \\ B \end{bmatrix} + (1-\beta) \begin{bmatrix} Y \\ Y \\ Y \end{bmatrix} \quad (1)$$

$$\beta = \min\left(\frac{1-L}{R^{out}-L}, \frac{1-L}{G^{out}-L}, \frac{1-L}{B^{out}-L}\right) \quad (2)$$

where

$$R^{out} = \begin{cases} R^{out} & \text{if } R^{out} > 1 \\ 1 & \text{if } R^{out} \leq 1 \end{cases}$$

$$G^{out} = \begin{cases} G^{out} & \text{if } G^{out} > 1 \\ 1 & \text{if } G^{out} \leq 1 \end{cases}$$

$$B^{out} = \begin{cases} B^{out} & \text{if } B^{out} > 1 \\ 1 & \text{if } B^{out} \leq 1 \end{cases}$$

Although the gamut of LHS and YIQ systems are different, given any R, G, or B values, the luminance in LHS and YIQ are the same. Changing saturation according to LHS or YIQ does not change the hue on either systems but only different amount of saturation according to the definition of each system.

During saturation clipping, given any RGB values that are out of the gamut of LHS or YIQ (i.e., out of the RGB cube), the RGB values will be clipped by the same amount according to LHS or YIQ saturation clipping. However, the original and resulted saturation according to LHS and YIQ will be different.

#### 4 Experiments

An experiment has been conducted to compare the performance of different clipping techniques. Figure 6 (a) shows the original image. After applying luminance histogram equalization process, many pixels are out of the gamut of the RGB coordinate system. Figure 6 (b), (c) and (d) show the result of clipping R, G, or B values, clipping luminance, and clipping saturation on the image after luminance histogram equalization process, respectively. The experiment shows that clipping saturation produce an image with the best contrast because each pixel is able to reach the expected luminance of the histogram equalization. The difference in contrast can be obviously seen on the faces and the hairs of the man and the woman, carpet, couch, and flowers.

#### 5 Conclusion

RGB color coordinate systems are employed for color image representation in computer applications, such as storage, camera, scanner, etc. However, it does not correspond to human perception; therefore, color coordinate systems such as LHS and YIQ are usually utilized in color image processing. Unfortunately, many pixels cannot be mapped to the RGB color cube after processing in LHS or YIQ space. Clipping techniques

are necessary to solve such problem. Tradition clipping techniques such as clipping RGB values or clipping luminance produce significant color or contrast distortion. In this paper, we propose to clip saturation. Graphical analysis of luminance clipping and saturation clipping is presented. Experiments are also conducted to show that the saturation clipping technique outperforms the other two clipping techniques.

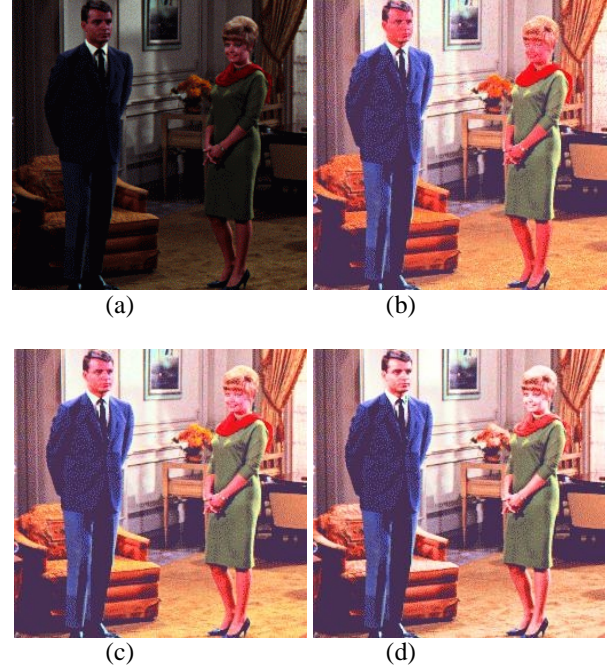

Figure 6: (a) original image, (b) clipping R, G, or B values after luminance histogram equalization, (c) clipping luminance after luminance histogram equalization, (d) clipping saturation after luminance histogram equalization.

#### 6 References

- [1] G. Marcu, and S. Abe, "Gamut Mapping For Color Simulation on CRT Devices," *Proceedings of SPIE*, vol. 2658, 1996.
- [2] A. R. Robertson, "Historical Development of CIE Recommended Color Difference Equations," *Color Research and Application*, vol. 15, pp. 167-170, June 1990.
- [3] A. R. Robertson, "The CIE 1976 Color-Difference Formulae," *Color Research and Application*, vol.2, Spring, 1977, p.7-11.
- [4] J. J. Rodriguez, and C. C. Yang, "Effects of Luminance Quantization Error on Color Image Processing," *IEEE Transactions on Image Processing*, vol. 3, no. 6, pp. 850-854, November 1994.
- [5] J. J. Rodriguez, and C. C. Yang, "High Resolution Histogram Modification of Color Images," *Graphical Models and Image Processing*, vol.57, no.5, September, 1995, pp.432-440.